

Installation Guide

For DC External POD Electric Thruster Models
SX35POD, SX50POD



SLEIPNER AS

P.O. Box 519

N-1612 Fredrikstad

Norway

www.sleipnergroupp.com

DOCUMENT ID: 6398

REVISION: 9

DATE: 2021

LANGUAGE: EN

MI

Installation Instructions

Considerations and Precautions	3
Thruster Measurements	4
Thruster Specifications.....	5
Technical Specifications	5
Control Box Technical Specifications.....	6
Positioning of the SX with Hydrodynamical Cover.....	7

Installation Instructions

Installation Considerations and Precautions.....	8
Grids or Cowls Assembly.....	9
Tunnel Installation.....	10
Hydropod Modification	11
Hydropod Installation.....	12
Propeller Installation.....	13
Control Box Installation.....	14
Thruster Electrical Installation.....	15 - 16
Electrical Specifications	17
Control Panel Cable Installation	18
Control Panel Installation	19

Pre-delivery Checklist	20
-------------------------------------	-----------

Service and Support	21
----------------------------------	-----------

Product Spare Parts and Additional Resources	21
---	-----------

Warranty statement	21
---------------------------------	-----------

Products

SM150536 | SXPOD-35/50-50MM - Hydropod complete kit for in water flow configuration

DECLARATION OF CONFORMITY

MC_0020



Sleipner Motor AS
P.O. Box 519, Arne Svendsensgt. 6-8
N-1612 Fredrikstad, Norway

Declare that this product with accompanying standard control systems complies with the essential health and safety requirements according to:

DIRECTIVE 2013/53/EU
DIRECTIVE 2014/30/EU
DIRECTIVE 2014/35/EU

It is the installers responsibility

When installing Sleipner equipment follow the outlined regulations/ classification rules (electrical/ mechanical) according to international or special national regulations. Instructions in this guide cannot be guaranteed to comply with global electric/ mechanic regulations/ classification rules.

Follow all health and safety laws in accordance with their local outlined regulations/ classification rules.

Before installation, it is important that the installer reads this guide to ensure necessary acquaintance with the product.

The recommendations made in this manual are guidelines ONLY, and Sleipner Motor AS (Sleipner) strongly recommend that before installation, advice is obtained from a naval architect familiar with the particular vessel and regulations/ classifications.

This manual is intended to support educated/ experienced staff and is therefore not sufficient in all details for professional installation. (NB: These instructions are only general instruction. If you are not skilled to do this work, please contact professional installers for assistance.)

All electrical work must be done by a licensed professional.

Faulty installation of Sleipner products will render all warranty given by Sleipner Motor AS void.

MC_0038

EN

Installation Considerations and Precautions

MC_0071

- Do not install the thruster in a position where you need to cut a stiffener/ stringer/ support for the hull integrity without checking with the boat builder this can be done safely.
- Contacts/ plugs or other joints in the control cables must be mounted so they remain dry at all times.
- We advise painting the gear house and propellers with anti-fouling. (NB: Do not paint the sealing/ rubber fittings or propeller shafts.)
- Do not finish the inside of the tunnel with a layer of gel-coat/ topcoat or similar. There is only room for a thin coat of primer and two layers of anti-fouling between the tunnel and the propellers.
- Keep installation within advised measurements. The entire surface is hard coated seawater resistant aluminium. Do not damage/penetrate the coat.
- The external stern thruster assembly and controller unit are ignition protected and can be installed in areas with the chance of explosive gases in accordance to ISO 8846 and ABYC c1500. (Certification pending)
- Ensure that the external stern thruster assembly does not disturb the water flow under the hull. At higher speeds, if the thruster is installed too low it can cause damage to the thruster and/ or add additional drag and unwanted water splashing.
- The recommended minimum tunnel depth from the water surface is 140mm (5,51') to the centre of tunnel diameter. Place the Thruster as deep as possible for better performance and reduced noise.
- When installing the thruster ensure it does not foul existing equipment inside the boat like motor bedding etc.
- If able ensure that stern-drives/ trim-tabs do not interfere with the water flow from the thruster as this can reduce the thrust effectiveness considerably. We recommend the use of our Sleipner cowls to enhance the performance and allow installation in shallow draft boats. Sleipner cowls will also minimise the effect if stern-drives/ trim-tabs obstruct the thruster.
- Ensure there is enough space both inside and outside the transom of the boat and the thruster does not get in conflict with existing equipment inside the boat like steering links etc. (NB: It is possible to mount the tunnel offset from the boat's centre line if necessary.)
- Heat protection cut off is calculated from the thruster motor. To avoid cable overheating do not install place the volt cables from the thruster to the control box near any heat sources.

EN

Thruster Installation Considerations and Precautions

MC_0257

Before installation, it is important that the installer reads this guide to ensure necessary acquaintance with this product.

- The electro motor must be handled with care. Do not lift it by internal cable connections, main terminals or placed down on the drive shaft.
- The thruster power supply circuit must include the recommended sized fuse and a battery isolation switch.
- Never run the thruster out of water.
- It is important to follow the guidelines in this manual. Failure can result in severe damage to the thruster.

NEVER

Disassemble any part of the Ignition Protected stern thruster assembly. Tampering with the Ignition Protected stern thruster assembly or any attempt to disassemble anything on this thruster assembly inside the boat can cause an explosion with severe consequences. If there is a problem with your Ignition Protected stern thruster, please contact your dealer.

MC_0267

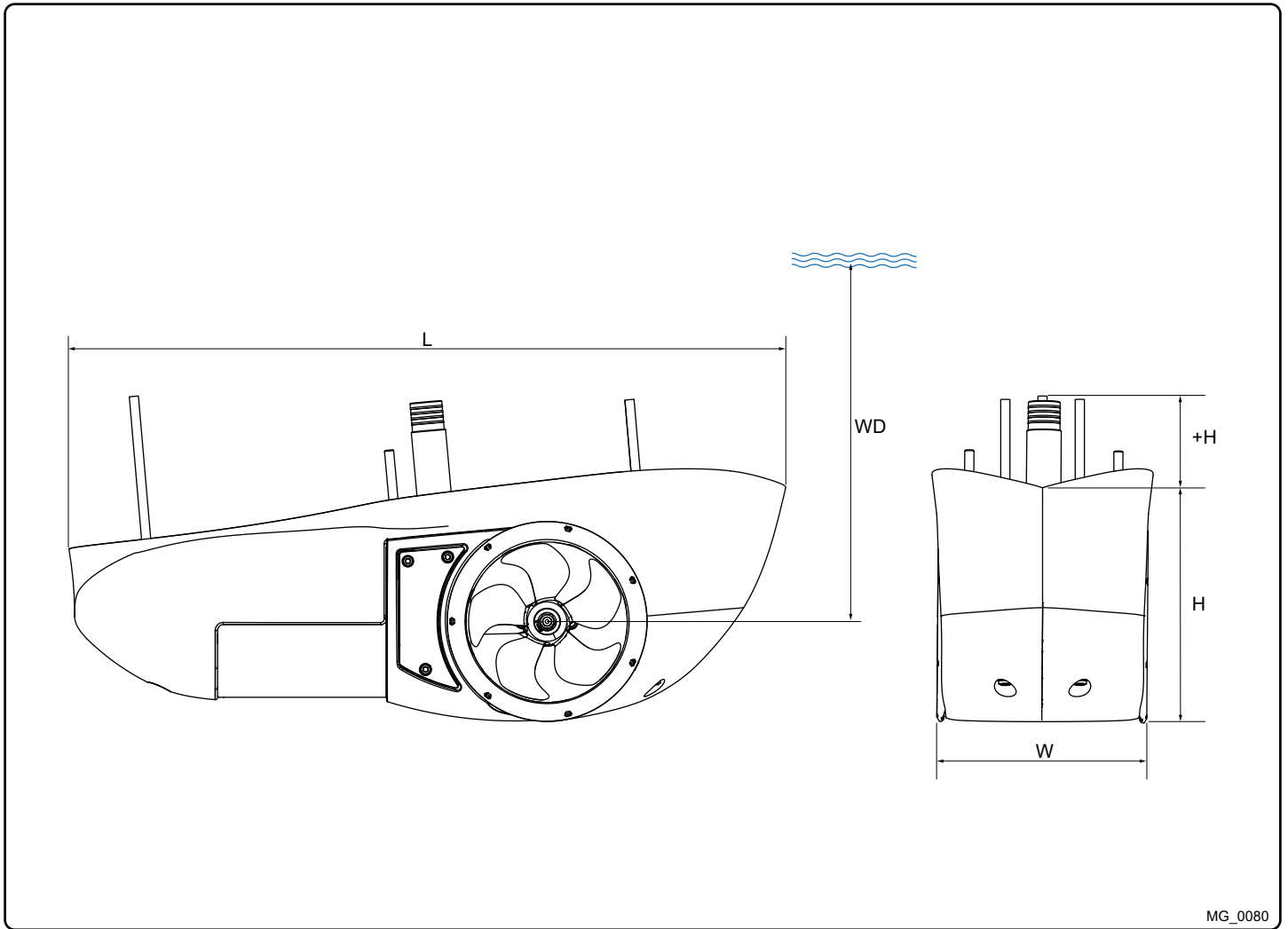

MG_0080

EN **Thruster Measurements** MC_0268

Measurement code	Measurement description	*35 12v		*50 12v	
		mm	inch	mm	inch
H	Mould Height	180	7,08	180	7,08
+H	Tube Height	183	7,20	183	7,20
W	Width	183	7,2	183	7,2
L	Length	630	24,8	630	24,8

*Valid for SX & SXP

Description	* 35	* 50
Available DC System (v)	12v	12v
Thrust 12v or 24v (kg * lbs)	43 kg * 94 lbs	62 kg * 136 lbs
Thrust 10.5v or 21v (kg * lbs)	35 kg * 77 lbs	50 kg * 110 lbs
Typical Boat Size (m * ft)	6m - 10m * 19ft - 32ft	8m - 11m * 27ft - 37ft
Propulsion System	Single	Single
Power (kw * Hp)	1.8kw * 2hp	2.8kw * 3.75hp
Weight (kg * lbs)	19.3 kg * 42.55 lbs	19.3 kg * 42.55 lbs

- Motor:** Custom made reversible DC-motor.
- Gear house:** Seawater resistant aluminium. Ball-bearing and ceramic axial seals at propeller shaft and a combination of ball bearing/ slide bearing at drive shaft. (Pre-filled and sealed for life)
- Motor bracket:** Seawater resistant aluminium, galvanically insulated from the motor..
- Tunnel:** Hydrodynamic fibreglass reinforced snap on composite.
- Propeller:** 5-blade skewback "Q-prop" propeller, fibreglass reinforced composite.
- Batteries:** Minimum recommended battery capacity (cold crank capacity by DIN/SAE standard)
Contact a battery supplier for more information.
- Max. Use:** 2 - 3 min. duty cycle at 20°
- Safety features:**
- Electronic time-lapse device protects against sudden change of drive direction.
 - The electric thermal cut-off switch in electro motor protects against overheating (auto-reset when electro motor cools down).
 - Original SLeipner panels shut off automatically 6 minutes after last use.
 - Original SLeipner panels use child-safe double ON buttons.
 - An integrated microprocessor monitors solenoids, reduce wear and risk of solenoid lock-in.
 - Auto-stop of the thruster occurs when an undesirable solenoid lock-in occurs or when continuous operation cut-off timer exceeds 3 minutes.

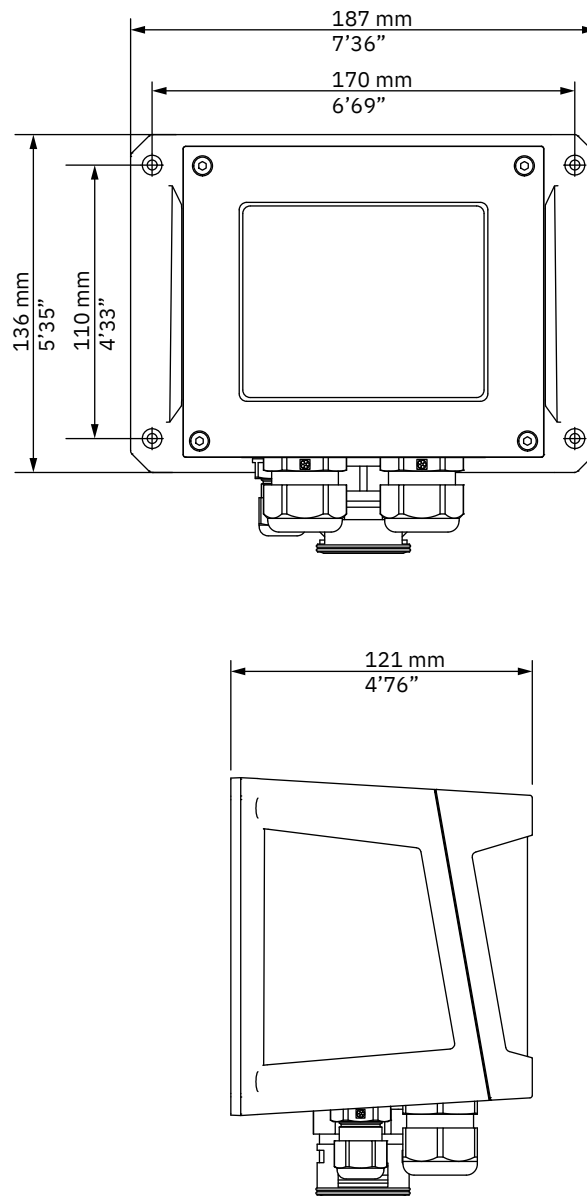

MG_0132



Control Box Technical Specifications

MC_0082

	SX35	SX50
Operation volts:	12v.	12v
Max Current:	250A	380A
Duty Cycle:	S2.	S2
Max ambient temp:	50°c	50°c
Min ambient temp:	-25°c	-25°c
Power supply cable:	35 - 70mm ² / AWG 2 - 00	35 - 70mm ² / AWG 2 - 00
Mount direction :	Any	Any

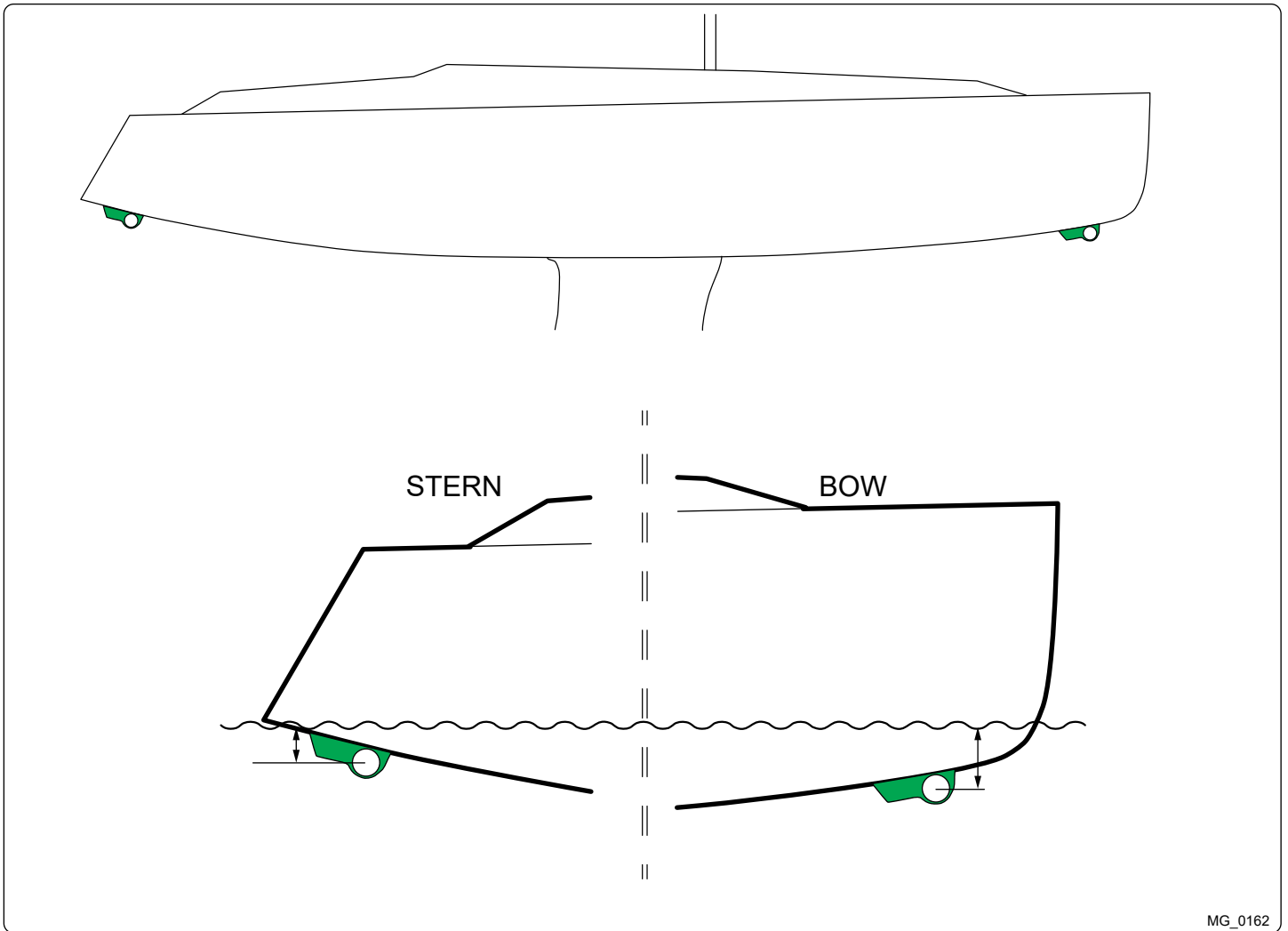

MG_0162

EN

Positioning of the SX with Hydrodynamical Cover

MC_0072

Aim to install the thruster as far forward/ Aft as possible

Due to the leverage effect around the boats' pivot point. The relative distance difference from the boat pivots' point to the thruster will determine the amount of real thrust for the boats, rotation.

It is the installers responsibility

When installing Sleipner equipment follow the outlined regulations/ classification rules (electrical/ mechanical) according to international or special national regulations. Instructions in this guide cannot be guaranteed to comply with global electric/ mechanic regulations/ classification rules.

Follow all health and safety laws in accordance with their local outlined regulations/ classification rules.

Before installation, it is important that the installer reads this guide to ensure necessary acquaintance with the product.

The recommendations made in this manual are guidelines ONLY, and Sleipner Motor AS (Sleipner) strongly recommend that before installation, advice is obtained from a naval architect familiar with the particular vessel and regulations/ classifications.

This manual is intended to support educated/ experienced staff and is therefore not sufficient in all details for professional installation. (NB: These instructions are only general instruction. If you are not skilled to do this work, please contact professional installers for assistance.)

All electrical work must be done by a licensed professional.

Faulty installation of Sleipner products will render all warranty given by Sleipner Motor AS void.

MC_0038

EN

Installation Considerations and Precautions

MC_0071

- Do not install the thruster in a position where you need to cut a stiffener/ stringer/ support for the hull integrity without checking with the boat builder this can be done safely.
- Contacts/ plugs or other joints in the control cables must be mounted so they remain dry at all times.
- We advise painting the gear house and propellers with anti-fouling. (NB: Do not paint the sealing/ rubber fittings or propeller shafts.)
- Do not finish the inside of the tunnel with a layer of gel-coat/ topcoat or similar. There is only room for a thin coat of primer and two layers of anti-fouling between the tunnel and the propellers.
- Keep installation within advised measurements. The entire surface is hard coated seawater resistant aluminium. Do not damage/penetrate the coat.
- The external stern thruster assembly and controller unit are ignition protected and can be installed in areas with the chance of explosive gases in accordance to ISO 8846 and ABYC c1500. (Certification pending)
- Ensure that the external stern thruster assembly does not disturb the water flow under the hull. At higher speeds, if the thruster is installed too low it can cause damage to the thruster and/ or add additional drag and unwanted water splashing.
- The recommended minimum tunnel depth from the water surface is 140mm (5,51') to the centre of tunnel diameter. Place the Thruster as deep as possible for better performance and reduced noise.
- When installing the thruster ensure it does not foul existing equipment inside the boat like motor bedding etc.
- If able ensure that stern-drives/ trim-tabs do not interfere with the water flow from the thruster as this can reduce the thrust effectiveness considerably. We recommend the use of our Sleipner cowls to enhance the performance and allow installation in shallow draft boats. Sleipner cowls will also minimise the effect if stern-drives/ trim-tabs obstruct the thruster.
- Ensure there is enough space both inside and outside the transom of the boat and the thruster does not get in conflict with existing equipment inside the boat like steering links etc. (NB: It is possible to mount the tunnel offset from the boat's centre line if necessary.)
- Heat protection cut off is calculated from the thruster motor. To avoid cable overheating do not install place the volt cables from the thruster to the control box near any heat sources.

EN

Thruster Installation Considerations and Precautions

MC_0257

Before installation, it is important that the installer reads this guide to ensure necessary acquaintance with this product.

- The electro motor must be handled with care. Do not lift it by internal cable connections, main terminals or placed down on the drive shaft.
- The thruster power supply circuit must include the recommended sized fuse and a battery isolation switch.
- Never run the thruster out of water.
- It is important to follow the guidelines in this manual. Failure can result in severe damage to the thruster.

NEVER

Disassemble any part of the Ignition Protected stern thruster assembly. Tampering with the Ignition Protected stern thruster assembly or any attempt to disassemble anything on this thruster assembly inside the boat can cause an explosion with severe consequences. If there is a problem with your Ignition Protected stern thruster, please contact your dealer.

MC_0267

Snaplock from
opposite tunnel half

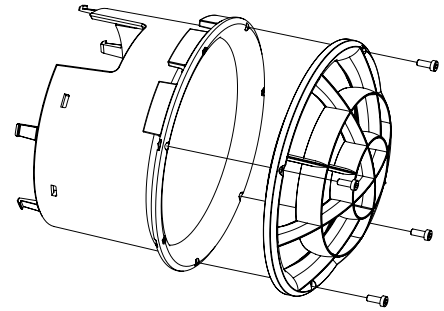
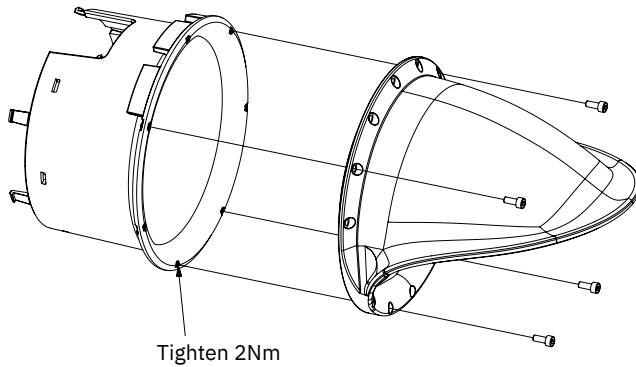
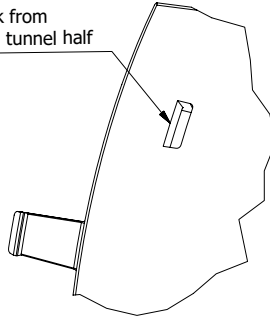

MG_0145

EN

Grids or Cowls assembly

MC_0074

1. Attach the cowls or grids with included bolts and washers. **(NB: Ensure the appropriate twist of the cowl to direct water away from obstacles)**
2. Attach the completed tunnels.

For retrofit

1. Remove propeller and the old tunnel. **(NB: the tunnel is not designed to be removed non-destructively. Break off the snap locks between the tunnel half ends by pushing a small screwdriver through the holes from the outside.)**
2. Follow the above installation process.

IMPORTANT

Remember the tunnel can not be removed without being destroyed.

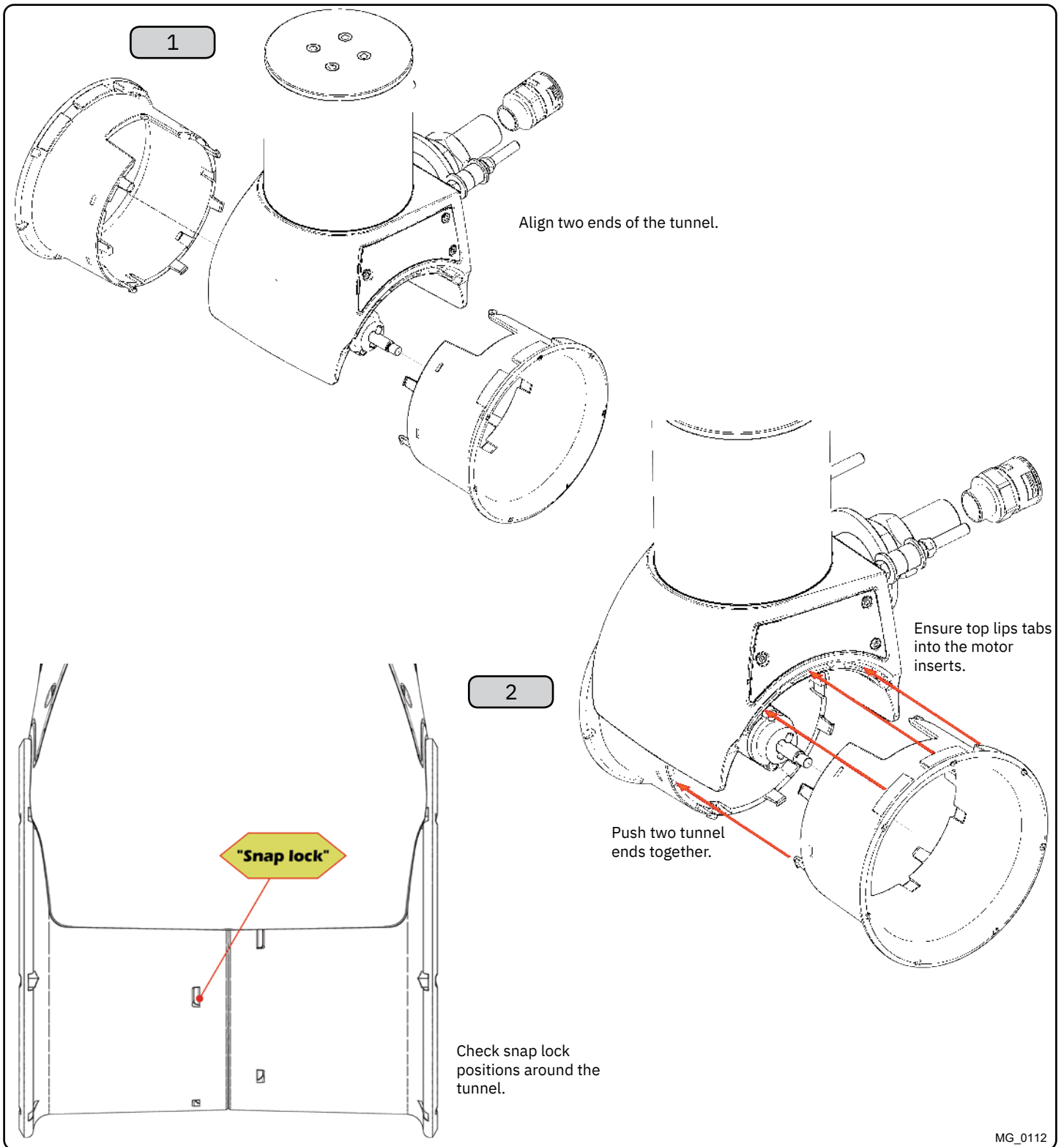

EN

Tunnel Installation

MC_0074

! Please refer to the graphic for special considerations relating to your model !

1. Ensure grids or cowls are installed if in use.
2. Connect both ends of the tunnel to the thruster motor. All hooks must be completely interlocked making the inside of the tunnel smooth. **(NB: Ensure tunnel moulding around the gear leg and tunnel top align.)**

IMPORTANT

Ensure all snap-lock positions are correctly connected into place.

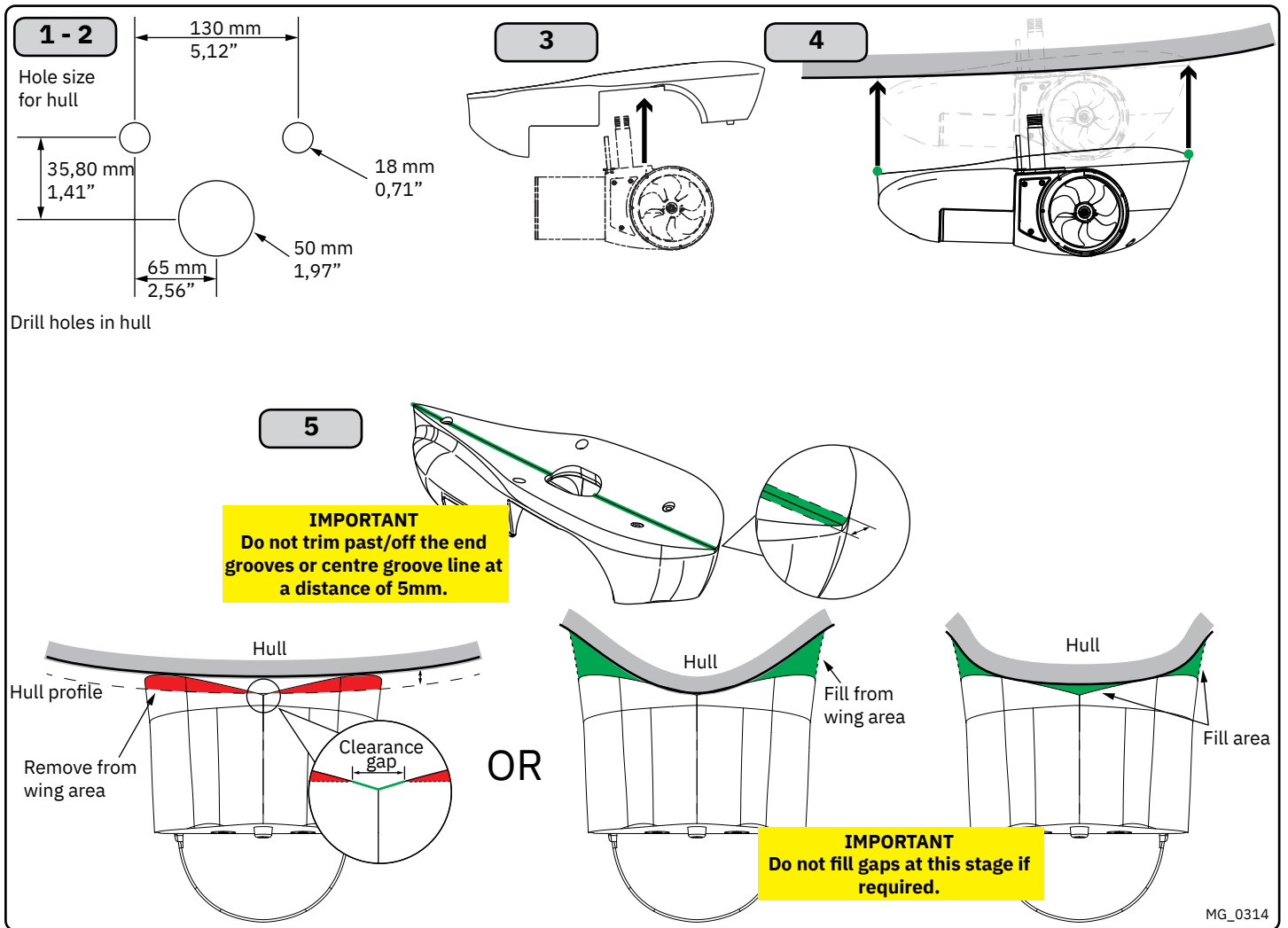

EN

Hydropod Modification

MC_0269

! Please refer to the graphic for special considerations relating to your model !

Define the location to install the thruster. **(NB: Ensure internally the thruster will not obstruct any objects. Ensure cables internally do not obstruct any objects. Do not place cables or control box close to high heat radiating parts EG. Turbo/ exhaust manifolds etc.)**

1. Mark the locations of the three drill holes for the SX thruster using the defined measurements or from a template to the hull. (NB: Maximum hull thickness is 50mm.)
2. Drill main hole for the cable tube, then two support bolt holes.
3. Place the SX thruster into the Hydro pod mould.
4. Place the hydro-pod with the SX thruster on the hull. Use the pre-drilled holes to guide the assembly to the desired location. **(NB: The SX thruster in the Hydro pod will ensure no flexing of the mould will occur)**
5. Modify the Hydro pod mould to match the hull profile of the boat. Aim to obtain both the front and back tips of the mould sit flush to the hull. Follow the below instructions depending on the modification required:

A) Trim the wings of the hydro pod to match the hull profile. **(NB: Excessive heat caused by the cutting method can cause the mould to melt in the worked area.)**

OR

B) Determine to use appropriate filler to fill the gap between the hydro pod and the hull. **(NB: Do not fill gaps at this stage if required.)**

IMPORTANT

Do not trim past/off the end grooves or centre groove line at a distance of 5mm.

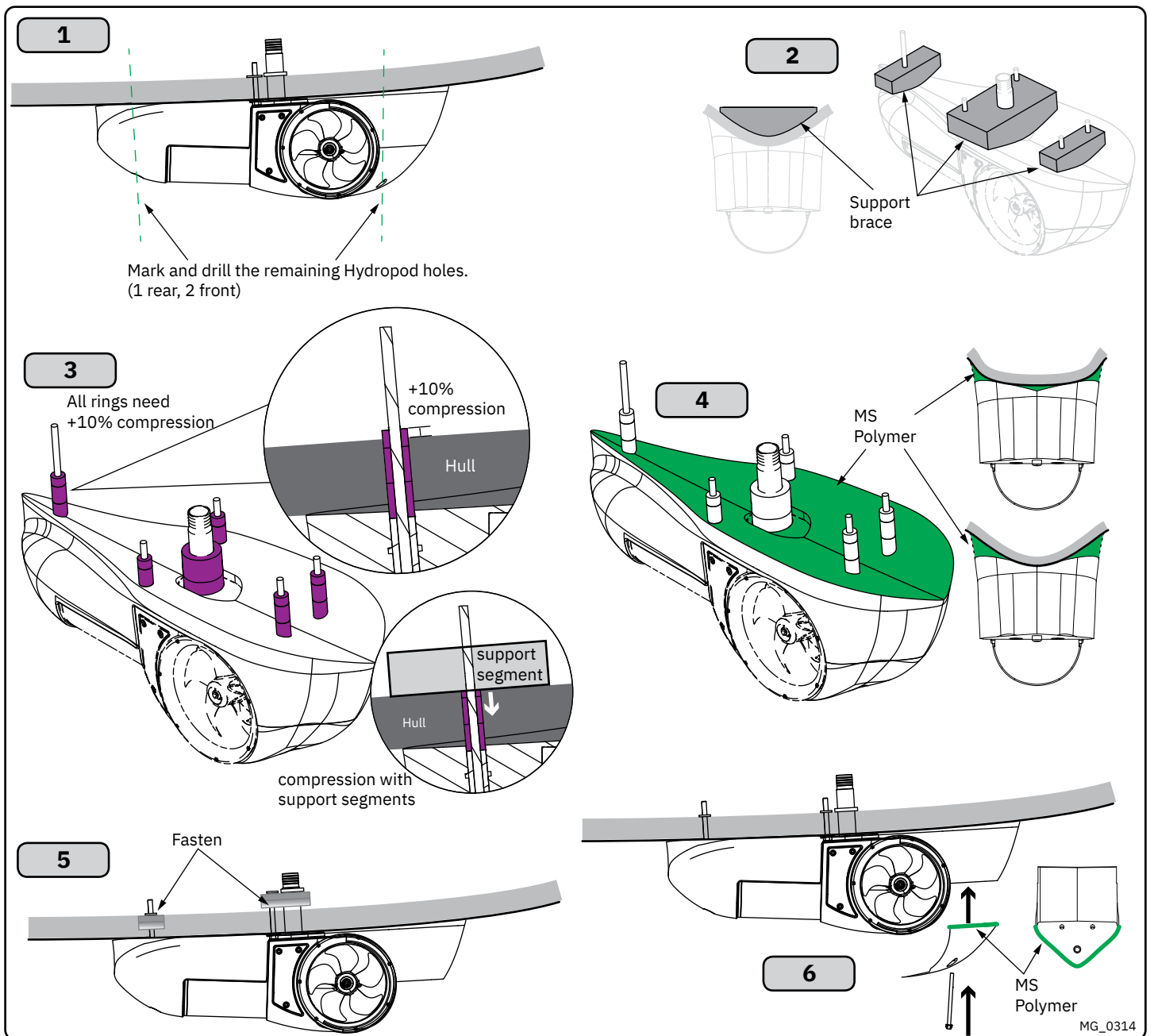

EN

HydroPod Installation

MC_0269

! Please refer to the graphic for special considerations relating to your model !

1. Temporarily fasten the Hydro pod to the hull using the SX thruster bolts. Mark the remaining Hydro pod holes (1 rear, 2 front) and drill holes. Clean the area from dust for installation of the thruster. **(NB: Tightening the Hydro pod can reduce the gap between the mould and the hull from compression. Note this when if required to add MS Polymer to fill gaps.)**
2. Make support segments based on the hull profile for the bolt and tube fasteners.
3. Check the length of the compression rings. Compression rings must be longer than hull thickness to allow for compression (NB: Cut compression sealants to length top achieve 15% compression.)
4. Apply a sealant (MS Polymer) to:
 - the inside surface of the cut-out holes on the hull.
 - To the surface of the washer to the thread and
 - in the recess of the main tube to the thread.
 - 1cm deep inside all compression ring.
 place all compression rings to bolt threads.
(NB: Ensure ample sealant (MS Polymer) around the bolts and centre tube for a watertight fitting.)
5. Place the Hydro pod to the hull without the nose cap. Fasten the Hydro pod via the SX thruster and back hydro pod securing bolt. **(NB: Wipe away MS Polymer that has been pushed out from the compression of the Hydro pod to the hull.)**
6. Place the Hydro pod nose cap and fasten nose cap securing bolt

IF: required to fill gaps between the Hydro pod and the hull use an appropriate amount on the Hydro pod mould to achieve this.

For installations in high corrosive environments (saltwater) the exposed aluminium parts of the thruster must be coated with an epoxy primer before antifouling or/and use.

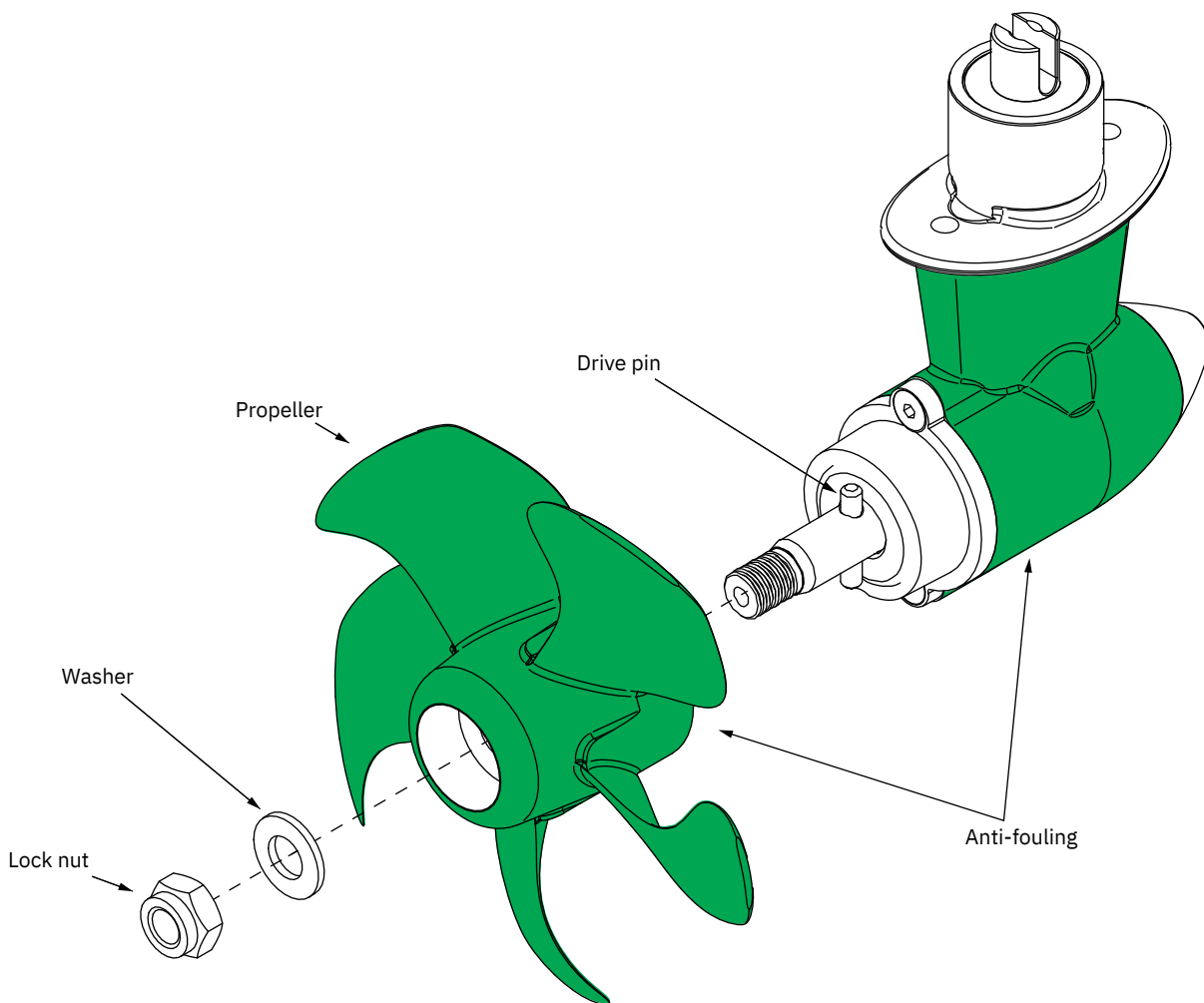

MG_0054

EN

Propeller Installation

MC_0016

! Please refer to the graphic for special considerations relating to your model !

1. Centre the drive pin and Insert the propeller onto the shaft spine. Rotate the propeller until the drive pin aligns with the internal slot in the propeller.
2. Insert the washer to the end of the shaft spline. Tighten with the propeller lock-nut.
3. Apply anti fouling to the gear leg and propeller. Do not apply anti fouling to any rubber elements of the gear leg or anodes.

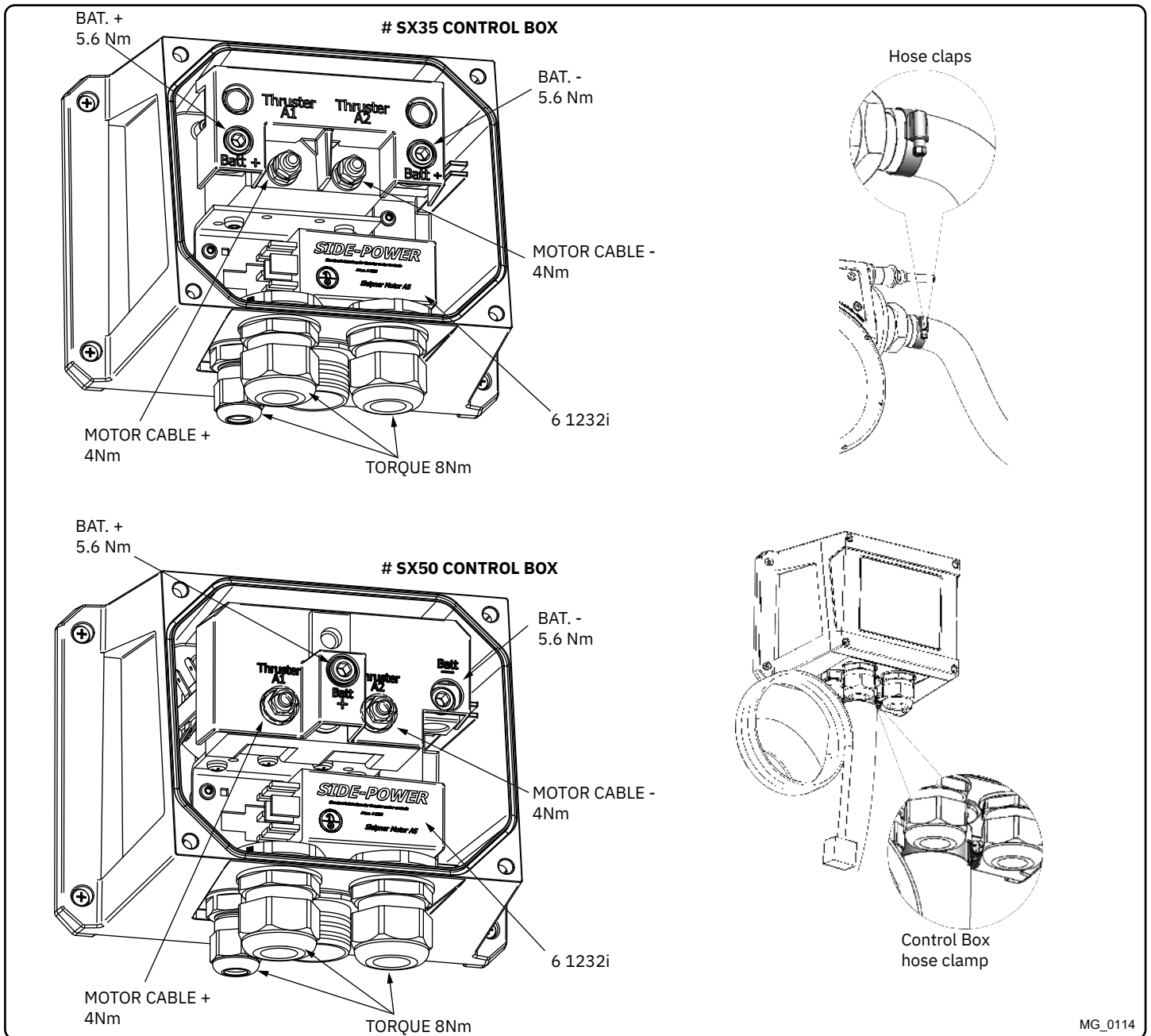

EN

Control Box Installation

MC_0075

! Please refer to the graphic for special considerations relating to your model !

The control box is the central component that can be connected to several other control panels. The control box can be mounted in any orientation, preferably with cables facing down. **(NB: The control box must be positioned within 0,75 meters from the thruster assembly with the provided cables and not near any object that radiate high temperatures.)**

1. Define the location to install the control box. **(NB: Ensure cables will not obstruct any objects.)**
2. Mark the locations of the four drill holes and drill the holes.
3. Attach cables to the control box **(NB: the control box internal components can be removed via its attachment screws for easier installation using thick battery cables.)**
4. Tighten hose clamps in order to ensure Ignition Protection as illustrated.
5. Fasten the control box to the hull.

IMPORTANT

It is the installers full responsibility to follow instructions and ensure total Ignition Protection.

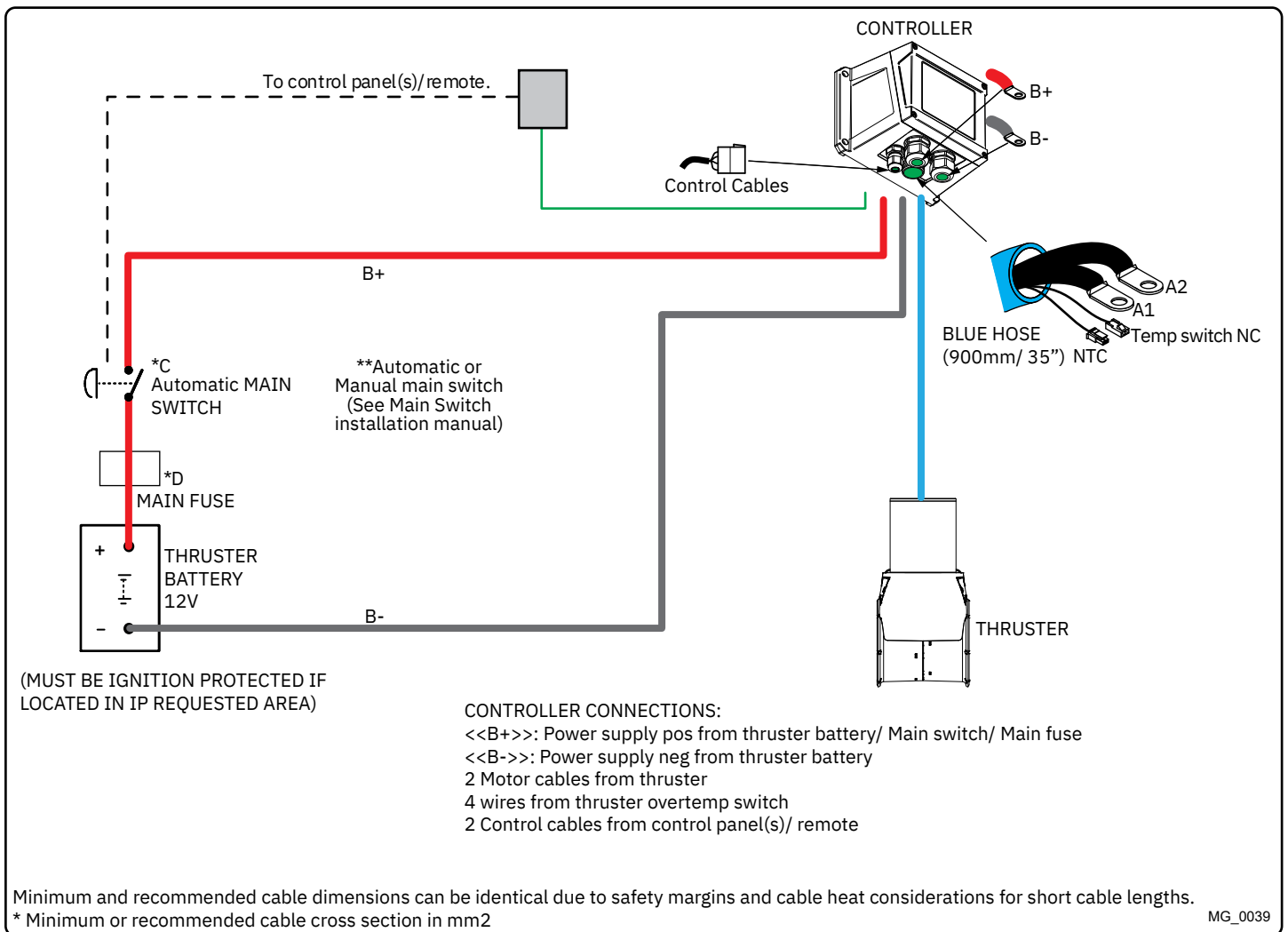

EN MC_0035

Thruster Electrical Installation

! Please refer to the graphic for special considerations relating to your model !

1. Information of electrical table. *see next page*
 - All power cable lengths represent the total length of the combined (+) and (-) cables.
 - Battery capacity is stated as minimum cold crank capacity, (CCA).
 - Use slow blow rated fuses to hold stated Amp-Draw for min. 5 minutes.
 - Consider the AMP hours (Ah) for your specific duty cycle.
2. Use appropriate sized cables and batteries with high cranking capacity to feed the thruster. The actual voltage at the motor while running the thruster decides the motors output RPM and thrust. Use larger cables and stronger batteries for better results.
 - See electrical specifications for advised minimum cables and batteries (CCA).
3. Connect the battery supply to the control unit (PPC).
 - Install a main manual/ automatic switch from the positive lead terminal on the battery PPC unit). The main switch must be accessible to turn off the thruster independently from the rest of the electrical operation of the vessel when not on-board or in emergencies. **(NB: It is advised to install a fuse on the positive cable for protection against short-circuiting of the main cables. The fuse should ensure no voltage decrease, slow-blow and sized to take the amperage draw for at least 5 minutes.)**
 - A circuit breaker can be used instead of the fuse and main power switch If the functionality is the same.

(NB: For Ignition Protected installations remember to use ignition protected fuses and switches if fitted in areas that require this feature. Ensure to follow your national regulations)

5. Cable lugs must have adequate electrical and mechanical isolation and fitted with cable lug covers.
6. Fasten cables to the required torque.

WARNING

Check the following with the main switch is set to off :

After all electrical connections have been completed check with an ohm meter that there is no electrical connection between

1. electro-motor flange and the positive terminal on the motor
2. electro-motor flange and the battery negative terminal on the motor

If unsure contact skilled personnel.

Thruster Electrical Installation

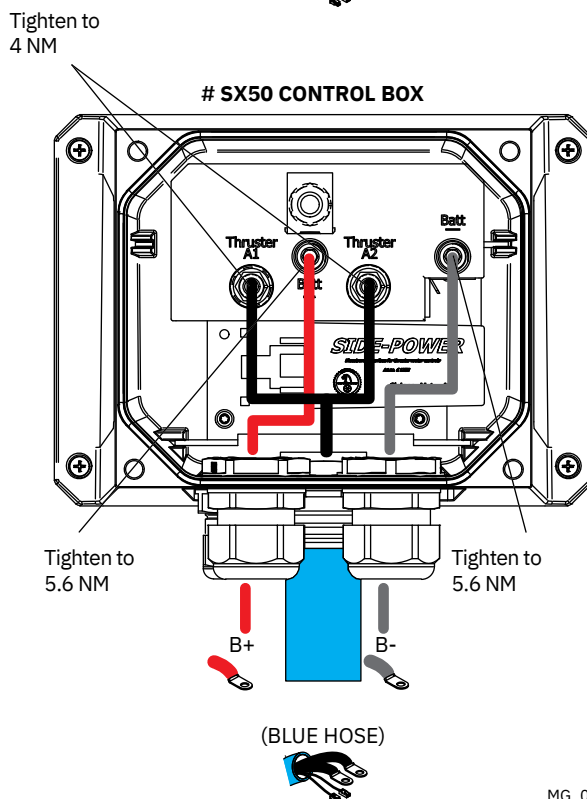
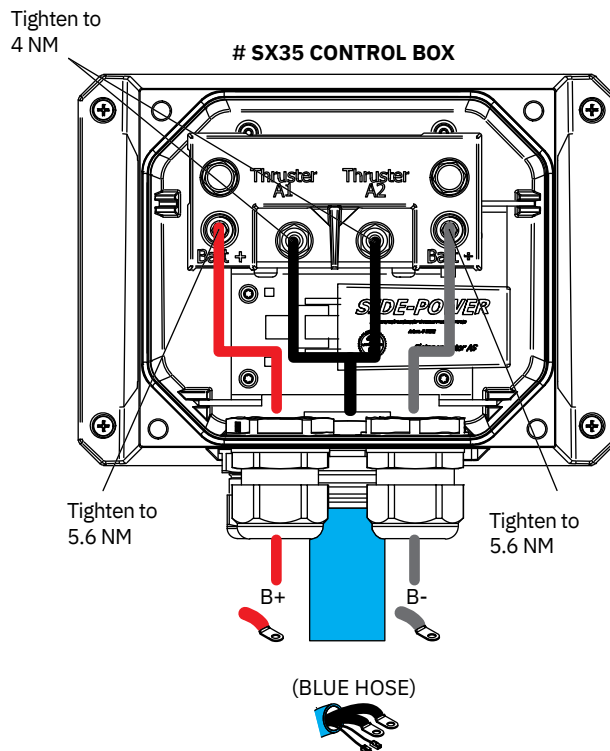
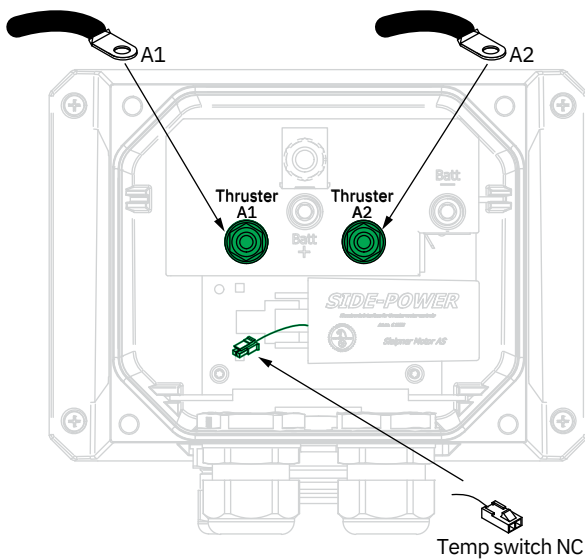
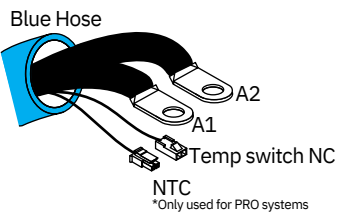
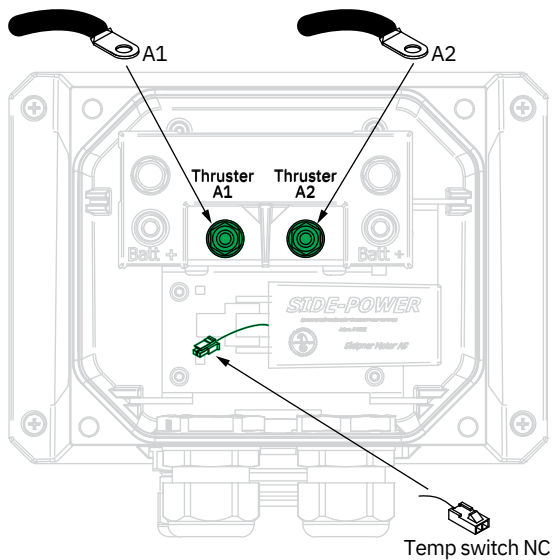
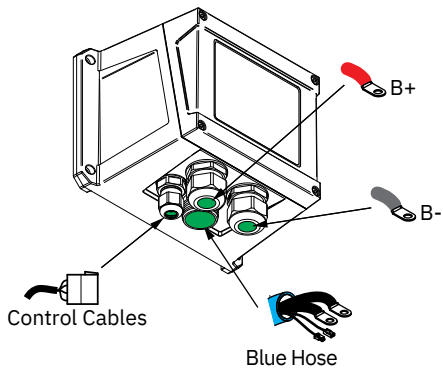

Model Size	System Voltage	Nominal current draw	Min. battery CCA	Rec. fuse	<7m total + & -		7-14m total + & -		15-21m total + & -		22-28m total + & -		28-35m total + & -		36-45m total + & -	
					Min.	Rec.	Min.	Rec.	Min.	Rec.	Min.	Rec.	Min.	Rec.	Min.	Rec.
					3	2	1/0	1/0	2/0	2/0	3/0	3/0	4/0	4/0	2 x 2/0	2 x 2/0
*35/140	12 V	245 A	DIN: 200 SAE: 380 EN: 330	ANL 150	mm2	50	70	70	95	120	120	120	120	120	2 x 70	2 x 95
					AWG	1/0	1/0	2/0	3/0	3/0	4/0	4/0	4/0	2 x 2/0	2 x 3/0	2 x 3/0
*50/1400	12 V	370 A	DIN: 350 SAE: 665 EN: 600	ANL 325	mm2	50	70	95	120	120	2 x 95	2 x 95	2 x 95	2 x 95	2 x 120	2 x 120
					AWG	1/0	2/0	3/0	4/0	4/0	2 x 2/0	2 x 2/0	2 x 3/0	2 x 3/0	2 x 3/0	2 x 4/0
24 V	170 A		DIN: 175 SAE: 332 EN: 280	ANL 150	mm2	25	25	35	50	50	50	50	50	70	70	
					AWG	3	3	2	2	1/0	1/0	1/0	1/0	2/0	2/0	

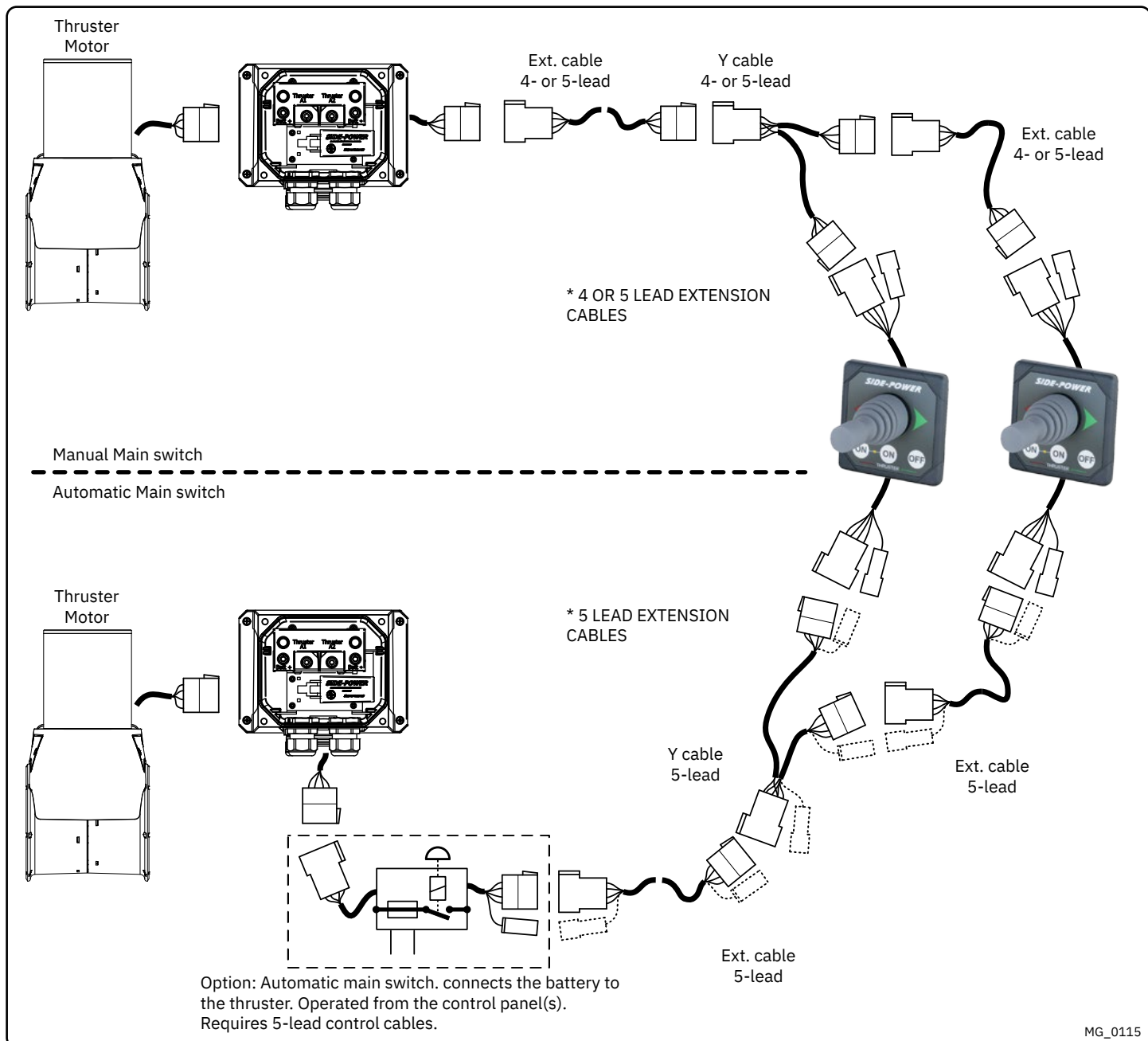

EN

Control Panel Cable Installation

MC_0041

! Please refer to the graphic for special considerations relating to your model !

- All Sleipner control panels can be used in any combination.
- All control panels can be installed using:
 - Y-connectors - for standard on/off
 - T-connectors - for S-link proportional power system.

(NB: If two or more control panels are operated at the same time in opposite directions, the electronic control box will stop the thruster until it receives a single signal or thrust in one direction.)

- Sleipner on/off equipment it is entirely “plug & play” and require no additional configuration setup.

See the Control panel manual for more information.

Example of control panels

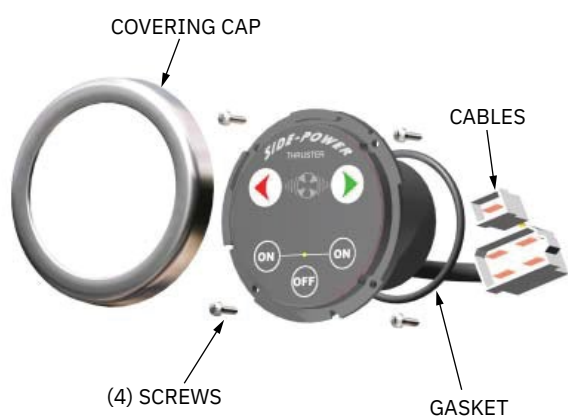

MG_0026

EN

Control Panel Installation

MC_0042

! Please refer to the graphic for special considerations relating to your model !

Find a suitable location for the control panel where it does not obstruct or is obstructed by other devices. Install the control panel on a flat surface where it is easy to use.

1. Use the supplied cut-out template to mark the area to remove on your control dash.
2. Cut out the area per template for the control panel. **(NB: If the front surface around your cut out is jagged or chipped, use a sealant to assist the gasket.)**
3. Place the gasket to the back face of the panel
4. Plug cables into the connectors at the rear of the control panel.
5. Insert the control panel in place and fasten screws.
6. Insert the control panels covering caps.

- Propeller is fastened correctly to the shaft.
- Propeller turns freely in tunnel.
- Primer and anti-fouling have been applied to the gear house and propeller but NOT on the anode or the gear house lid where the propeller is fastened.
- Correct drive direction as per control panel.
- The bolts holding the thruster are tightened correctly.
- The bolts holding the motor to its bracket are tightened correctly.
- All electrical connections are clean, dry and tight, and the correct cable, fuse and main switch size.
- No water leakage around hull penetrated studs
- Check that there is no electrical connection between the electro motor body and positive terminal on the motor, and between the electro motor body and the negative (A1) terminal on the motor with an ohm meter.

The thruster has been installed as per the instructions in this manual and all points in checklist above have been controlled.

Signed:

Date:

Extra pre-delivery tests by installer / yard who does not use other quality control systems !

Thruster type:

Serial number:.....

Date of delivery:.....

Correct drive direction as per control panel:

The compartment for the thruster has been isolated from general bilge water and has no obvious or suspected risks for flooding:

.....
.....
.....

Other comments by installer:

.....
.....
.....

Find your local professional dealer from our certified worldwide network for expert service and support.

visit our website www.sleipnergroun.com/support

For additional supporting documentation, we advise you to visit our website www.sleipnergroun.com and find your Sleipner product.

1. Sleipner Motor AS (The "Warrantor") warrants that the equipment (parts, materials and embedded software of products) manufactured by the Warrantor is free from defects in workmanship and materials for the purpose for which the equipment is intended and under normal use and service (the "Warranty").
2. This Warranty is in effect for two years (Leisure Use) or one year (Commercial and other Non-leisure Use) from the date of purchase by the end user (for demonstration vessels, the dealer is deemed as end user).
3. This Warranty is transferable and covers the equipment for the specified warranty period.
4. The warranty does not apply to defects or damages caused by faulty installation or hook-up, abuse or misuse of the equipment including exposure to excessive heat, salt or fresh water spray, or water immersion except for equipment specifically designed as waterproof.
5. In case the equipment seems to be defective, the warranty holder (the "Claimant") must do the following to make a claim:
 - (a) Contact the dealer or service centre where the equipment was purchased and make the claim. Alternatively, the Claimant can make the claim to a dealer or service centre found at www.sleipnergroun.com. The Claimant must present a detailed written statement of the nature and circumstances of the defect, to the best of the Claimant's knowledge, including product identification and serial nbr., the date and place of purchase and the name and address of the installer. Proof of purchase date should be included with the claim, to verify that the warranty period has not expired;
 - (b) Make the equipment available for troubleshooting and repair, with direct and workable access, including dismantling of furnishings or similar, if any, either at the premises of the Warrantor or an authorised service representative approved by the Warrantor. Equipment can only be returned to the Warrantor or an authorised service representative for repair following a pre-approval by the Warrantor's Help Desk and if so, with the Return Authorisation Number visible postage/shipping prepaid and at the expense of the Claimant.
6. Examination and handling of the warranty claim:
 - (a) If upon the Warrantor's or authorised service Representative's examination, the defect is determined to result from defective material or workmanship in the warranty period, the equipment will be repaired or replaced at the Warrantor's option without charge, and returned to the Purchaser at the Warrantor's expense. If, on the other hand, the claim is determined to result from circumstances such as described in section 4 above or a result of wear and tear exceeding that for which the equipment is intended (e.g. commercial use of equipment intended for leisure use), the costs for the troubleshooting and repair shall be borne by the Claimant;
 - (b) No refund of the purchase price will be granted to the Claimant, unless the Warrantor is unable to remedy the defect after having a reasonable number of opportunities to do so. In the event that attempts to remedy the defect have failed, the Claimant may claim a refund of the purchase price, provided that the Claimant submits a statement in writing from a professional boating equipment supplier that the installation instructions of the Installation and Operation Manual have been complied with and that the defect remains.
7. Warranty service shall be performed only by the Warrantor, or an authorised service representative, and any attempt to remedy the defect by anyone else shall render this warranty void.
8. No other warranty is given beyond those described above, implied or otherwise, including any implied warranty of merchantability, fitness for a particular purpose other than the purpose for which the equipment is intended, and any other obligations on the part of the Warrantor or its employees and representatives.
9. There shall be no responsibility or liability whatsoever on the part of the Warrantor or its employees and representatives based on this Warranty for injury to any person or persons, or damage to property, loss of income or profit, or any other incidental, consequential or resulting damage or cost claimed to have been incurred through the use or sale of the equipment, including any possible failure or malfunction of the equipment or damages arising from collision with other vessels or objects.
10. This warranty gives you specific legal rights, and you may also have other rights which vary from country to country.

At Sleipner we continually reinvest to develop and offer the latest technology in marine advancements. To see the many unique designs we have patented visit our website www.sleipnergroun.com/patents

© Copyright Sleipner Motor AS, 2021

The information given in the document was correct at the time it was published.

However, Sleipner Motor AS can not accept liability for any inaccuracies or omissions it may contain. Continuous product improvement may change the product specifications without notice.

Therefore, Sleipner Motor AS can not accept liability for any possible differences between product and document.

Register your product and learn more at www.sleipnergroun.com



SLEIPNER AS

P.O. Box 519

N-1612 Fredrikstad

Norway

www.sleipnergroun.com

Made in Norway

